

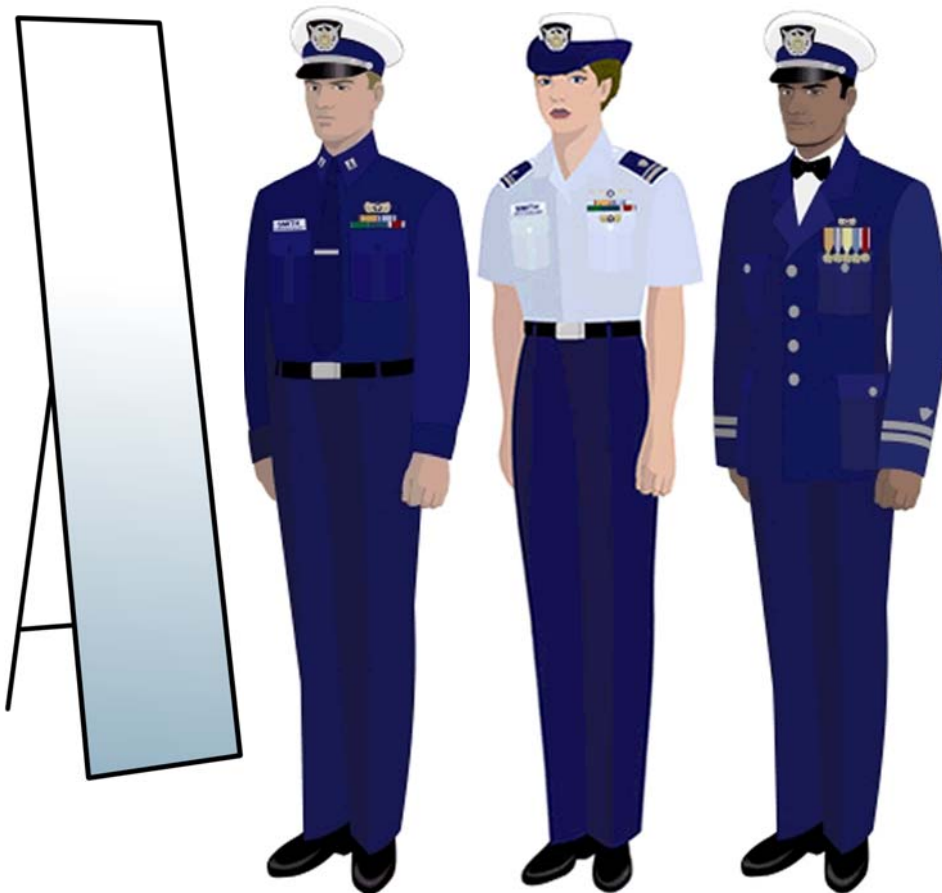

*UNITED STATES
COAST GUARD
AUXILIARY*



UNIFORM PROCUREMENT GUIDE



How do we look?

TABLE of CONTENTS

Uniform Procurement Guide Policy	3
Purpose and General Comments	5
Men's - Table A.....	6
Working Blue	
Undress Blue Summer - (Bravo).....	
Undress Blue Summer - (Alpha)	
Undress Blue Winter.....	
Operational Dress Uniform (ODU)	
Men's - Table B.....	7
Winter Dress Blue.....	
Tropical Blue Long.....	
Service Dress Blue - (Bravo)	
Dinner Dress White Jacket	
Women's - Table A	8
Working Blue	
Undress Blue Summer - (Bravo).....	
Undress Blue Summer - (Alpha)	
Undress Blue Winter.....	
Operational Dress Uniform (ODU)	
Women's - Table B	9
Winter Dress Blue.....	
Tropical Blue Long.....	
Service Dress Blue - (Bravo)	
Dinner Dress White Jacket	
Uniform Accessories.....	10
Proper Positioning of Collar Insignia.....	11
Proper Positioning of Garrison Cap Insignia and Device.....	11
Proper Positioning of Ribbons, Name Tag Qualification Devices	12
Proper Positioning of Belt, Buckle and Cover.....	13

TABLE of CONTENTS *(Continued)*

Uniform Vendors.....	14
Uniform Distribution Center.....	14
Exchanges: Coast Guard, Navy, Army and Air Force.....	18
U.S. Navy Exchange (NEX).....	19
U.S. Coast Guard Auxiliary Center (AUXCEN).....	20
U.S. Navy Support Center	23
U.S. Coast Guard Academy Clothing Locker.....	23
Kingform Cap Company Inc.....	24
Lighthouse Uniform Company	26
Propper International Co. (All Weather Parka).....	28
Ribbons and Medals, Standard or Magnetic (purchase).....	31
Sew-On Insignia and Devices	32
Maintenance of all things Uniform, (helpful hints).....	37
Uniforms: When to Wear and How to Coordinate.....	40
In Closing (things to remember)	41

The New UPG Policy

POLICY OF REVISION:

The Uniform Procurement Guide for the Coast Guard Auxiliary is currently undergoing revision. Changes to the UPG will now be a continual process. Instead of one revision being made on a yearly basis, revisions and clarifications will be posted in the UPG copy on the Personnel Department and Uniform Division web site at: auxpdept.org, throughout the year, as necessary. This new policy is being implemented in order to eliminate any errors, mistakes, and general forms of misinformation etc, and instead produce a centralized, final resource for timely, accurate information. All information placed in the UPG will be done so by the Division Chief of Uniforms - who is therefore solely responsible for its content. The policy of timely revision will commence immediately. Any and all questions regarding any information contained in the UPG should be sent to the Division Chief, Uniforms (DVC-PX), at pelagic200@aol.com. Any inquiries will be processed immediately and responded to accordingly.

NEW ACCESSIBILITY:

In the near future, the most recent Uniform Procurement Guide will be located on the Uniform Division Web page and on the Personnel Department web site. This will be the only Internet site where revisions to the UPG will be available; thus affording centrality and allowing the Division Chief unilateral access to the guide where updates, deletions, additions and other general revisions will occur. If a copy of the continually revised guide is extracted and used as an information tool of any form or fashion, it is the responsibility of the party doing so to maintain its accuracy. This can be done by constantly checking the UPG on the Personnel Department and Uniform Division web site for any updates.

SECURING A COPY:

How do I obtain a Hard Copy?

During the fourth quarter of every year, a copy of the UPG currently available on the web page (a compilation of all changes from the past 10 months or so), will be sent to the Auxiliary National Supply Center (ANSC) for printing in hard copy. When the copy is available for distribution it should begin sometime in late January or early February. When available, your FSO-MA will be able to order a limited supply from the ANSC. If for some reason you do not get a copy, simply provide an email, a snail mail, a phone call or a smoke signal to your FSO-MA, and the member will have the most recently compiled annual hard copy obtained for them. Please do not stockpile (there will not be as many printed as in the past), as the UPG will be DOWNLOADABLE from either site. This will save a lot of TREES, and again, make the LATEST INFORMATION READILY ACCESSABLE to the membership.

- ▶ It must be noted that any hard copies distributed by the ANSC are subject to continual change throughout the year.
- ▶ A hard copy is not your final reference for Uniform information unless it is identical to the copy posted in electronic form on the Division web page.

How do I obtain the Most Recent Copy?

The most recently updated copy of the UPG will be downloadable from the Personnel Department web site and the Uniforms Division page in PDF format.

- ▶ As stated above, there will be clarifications and changes made to the UPG throughout the year; these will be posted on the Personnel Department's "What's New" web page and on the National web page at www.nws.cgaux.org.
- ▶ As changes are posted on the Personnel Department's "What's New" web page, the electronic copy of the UPG will be updated simultaneously.

STAYING ATTENTIVE:

As stated above, an annual compilation of UPG revisions will be issued by the ANSC, and should be in hard copy by January or, at the latest, early February of every year. However, members are expected to stay abreast of revisions as they occur throughout the year. These changes will be on the Personnel Department "What's New" Website, and the revised UPG will be available in electronic form on the Uniform Division web site.

Please be advised that members who do not have immediate access to a computer (and they are to be considered) should be aware of changes or revisions made to the UPG as posted on the P-Dept. web site. It is to the member's benefit to acquire any new revision to the guide to revise their personal copies, as they become available. I would like to encourage any individual member in such a situation to exhaust your resources, such as the computers at your local library for one, or perhaps collaborate with a fellow member who has a computer. It is very important to stay on top of the web site. Inquire of the Uniform Division for alternative suggestions.

TO PONDER:

I would like at this time to say that we are a TEAM, we must all pull together to strengthen this TEAM. This is all about showing how devoted we are to the Coast Guard Family, of which we are a very important part. The uniform we wear is that of a United States Coast Guard Team that has a history of courage and bravery second to none. Let's take our "How Do We Look" Campaign to heart and wear our Auxiliary Uniform smartly and proudly!

PURPOSE:

The UNIFORM PROCUREMENT GUIDE is designed to give Auxiliarists the latest in-depth OFFICIAL policy and information covering uniform garments, sources of supply, ordering procedures, helpful size charts, prices and who to contact for assistance when purchasing garments. The GUIDE contains complete information on what uniforms to order and how to wear the Operational Dress Uniform correctly.

GENERAL:

All Auxiliarists have a responsibility to wear the uniform correctly. The UPG will help you find and purchase uniform items and provide you with valuable tips on how to wear the uniform correctly. Please take a few minutes to check out the latest edition of the UPG, (it is posted on the Personnel Department web page at www.auxpdept.org). The UPG includes information from both military and commercial sources. Each source of supply is listed with their procedures for ordering and returns. Return policies vary with suppliers. Be certain you understand what the supplier's return policies are before ordering.

It is the responsibility of members to purchase and maintain a uniform appropriate to the activities in which they will participate. All uniform purchases are tax deductible. Auxiliarists should have at least two uniforms, one for Dress and one for Work. Without a uniform, members are limited in what they can do. Uniforms are required for Public Education Classes, Patrols/Operations and Public Affairs Booth. They are needed when standing watches or providing other assistance at Coast Guard units. Finally, they serve to show that you are a member of the Coast Guard Auxiliary. Tables 1A and 1B for Men and 2A and 2B for Women specify each authorized uniform, when to wear. It also tells what uniform combinations to wear for assigned and routine occasions. In order to make these tables more user friendly, the format lists the items from head to toe (starting with the hat). Use this sheet as a helpful guide when ordering any uniform items. Pictures of all authorized uniforms are in the new AUXILIARY MANUAL, COMDTINST M16790.1F, including the Operational Dress Uniform.

MEN'S AND WOMEN'S TROPICAL BLUE LONG UNIFORM:

Members should consider purchasing the Tropical Blue Long uniform with the dress serge trousers and/or skirt. This basic uniform can be worn for most Auxiliary activities. The NEW Tunic with epaulets, pockets, and button placket in exactly the same location as the women's Tropical Blue shirt, is now authorized for women who would be more comfortable in a more loosely fitting shirt. The Tunic shirt worn with the dress serge trousers and/or skirt, Tropical Blue Long uniform (with short sleeve shirt with epaulets), and the Service Dress Blue Bravo are the dress uniforms year round. Even though the Coast Guard discontinued the Service Dress Blue (Alpha) uniform in July 2003, it still remains an approved uniform for Auxiliary wear. While it is moderately expensive to buy and maintain a complete set of dress, work, and formal uniforms, it need not be costly to own one uniform initially. See table 1B for Men and 2B for Women.

OPERATIONAL DRESS UNIFORM (ODU):

The Uniform Distribution Center is fully stocked with all items for composing a uniform. Go to: <http://www.uscg.mil/hq/g-w/g-wp/udc>

MEN'S AUXILIARY UNIFORMS

Table 1A

	Working Blue*	Undress Blue Summer - Bravo**	Undress Blue Summer - Alpha	Undress Blue Winter	ODU Unisex
Occasion	VSC's and Operations	VSC's, Classroom and Operations	Classrooms, meetings, boating safety booths	Classrooms, meetings, boating safety booths	Operations
Hat	Unit ball cap with metal collar device or utility cap with cap device	Unit ball cap with metal collar device or utility cap with cap device	Combination Cap or Garrison Cap	Combination Cap or Garrison Cap	Ball Cap Or Tilley Hat
Shirt	CG dark blue working shirt - short or long sleeves	Light blue short sleeve shirt w/ epaulets	Light blue short sleeve shirt w/ epaulets	Light blue, long sleeve, with epaulets	ODU Top CG Blue
Tie	None	None	None	CG blue 4-in Hand or optional clip-on	None
Trousers	CG Blue Undress	CG Blue Utility	CG Service Dress	CG Service Dress	ODU CG Blue
Socks	Black	Black	Black	Black	Black
Shoes	Blue, white or brown boat shoes	Blue, white or brown boat shoes	Black Dress Shoes	Black Dress Shoes	Safety boots, low top shoes, or boat shoes***
Gloves	None	None	None	Black (Optional)	None
Insignia	Sew on or metal collar devices	Metal collar devices	Metal collar devices	Enhanced or soft shoulder boards	Sew on or metal collar devices
Ribbons Medals Breast Device	Sew on or metal coxswain device - no ribbons	Auxiliary qualification devices -- no ribbons	Auxiliary qualification devices -- no ribbons	Auxiliary qualification devices -- no ribbons	Sew on or metal Qualification Devices No ribbons
Name Tags	Sew on name tags / USCG Auxiliary tape	Plastic name tag	Plastic name tag	Plastic name tag	Sew on name tags / USCG Auxiliary tape
Accessories	Wooly Pulley or Cardigan sweater / Black web belt with silver buckle and tip	Wooly Pulley or Cardigan sweater / Black web belt with silver buckle and tip,	Wooly Pulley or Cardigan sweater / Black web belt with silver buckle and tip	Wooly Pulley or Cardigan sweater / Black web belt with silver buckle and tip	Black Web Belt with Black Metal Tip Black subdued - open frame buckle
Authorized Outer Garment	Windbreaker, a weather parka, work jacket	Windbreaker, work jacket, all weather parka, reefer, overcoat, trench coat,	Windbreaker, all weather parka, reefer, overcoat, trench coat,	Windbreaker, all weather parka, reefer, overcoat, trench coat	Windbreaker, all weather parka, Work jacket

* Coast Guard discontinued uniform (08/09/2005). Auxiliarists can wear uniform until unserviceable.

** Can be worn until trousers (Coast Guard Blue Utility) unserviceable. No other trousers can be worn with this uniform at this time.

*** Safety boots, low top shoes (the dress oxford), or boat shoes (dark brown - leather laced) may be prescribed in special cases or for medical reasons.

MEN'S AUXILIARY UNIFORMS

Table 1B

	Winter Dress Blue	Tropical Blue	Service Dress Blue - Bravo	Dinner Dress White, Black Jacket
Occasion	In lieu of Service Dress Blue, except where a jacket and tie are appropriate	Authorized all year for meetings, classroom, official functions	Authorized all year for meetings, classroom, official functions	Formal Evening Occasions
Hat	Combination Cap or Garrison Cap	Combination Cap or Garrison Cap	Combination Cap or Garrison Cap	Combination Cap
Shirt	CG dark blue - long sleeve	Light blue shirt sleeve shirt with epaulets	Light blue long or short sleeve shirt with epaulets	White Formal
Tie	CG blue 4-in Hand or optional clip-on	None	CG blue 4-in Hand or optional clip-on	Black Bow Tie
Coat	None	None	Service Dress CG Blue coat w/ silver buttons	White mess jacket (summer) / Black mess jacket (winter)
Trousers	CG Service Dress	CG Service Dress	CG Service Dress	Formal blue, high waisted
Socks	Black	Black	Black	Black
Shoes	Black Dress Shoes	Black Dress Shoes	Black Dress Shoes	Black Dress Shoes
Gloves	Black (optional)	None	Black (optional)	White
Insignia	Metal collar devices	Enhanced or soft shoulder boards	Full sleeve lace on coat & shoulder boards on shirt	Hard shoulder boards/ white jacket; Full sleeve lace/ black jacket
Ribbons Medals Breast Device	Auxiliary qualification devices and Ribbons	Auxiliary qualification devices and Ribbons	Devices and Ribbons on coat	Miniature medals & devices; AUXOP & Past Officer
Name Tags	Plastic name tag	Plastic name tag	Plastic name tag	None
Accessories	Wooly Pully or Cardigan sweater / Black web belt with silver buckle and tip	Wooly Pully or Cardigan sweater / Black web belt with silver buckle and tip	Black belt with silver buckle and tip	Silver Cummerbund; suspenders optional
Authorized Outer Garment	Windbreaker, all weather parka, reefer, overcoat, trench coat	Windbreaker, all weather parka, reefer, overcoat, trench coat	Reefer, all weather parka, overcoat, trench coat	Trench coat, overcoat

NOTE: The Service Dress Blue (Alpha) is still approved for Auxiliary wear for solemn occasions, such as funerals, ceremonies, after 6 p.m. and for social activities. The uniform consists of Service Dress Blue Jacket, Blue Serge Dress Trousers, White Long Sleeved Shirt, Blue Four - In-Hand Neck Tie, Black Belt, Black Socks & Black Dress Shoes. Only the Combination Cap is appropriate for wear with this uniform.

WOMEN'S AUXILIARY UNIFORMS

Table 2A

	Working Blue*	Undress Blue Summer - Bravo**	Undress Blue Summer - Alpha	Undress Blue Winter	ODU Unisex
Occasion	VSC's and Operations	VSC's and Operations	Classrooms, meetings, boating safety booths	Classrooms, meetings, boating safety booths	Operations
Hat	Unit ball cap with metal collar device or utility cap with cap device	Unit ball cap with metal collar device or utility cap with cap device	Combination Cap or Garrison Cap	Combination Cap or Garrison Cap	Ball Cap Or Tilley Hat
Shirt	CG dark blue working shirt -short or long sleeves	Light blue short sleeve shirt w/ epaulets	Light blue short sleeve shirt w/ epaulets	Light blue, long sleeve, with epaulets	ODU Top CG Blue
Tie	None	None	None	Blue Tab Tie	None
Slacks/Skirt	CG blue undress slacks	CG Blue Utility	CG Service Dress slacks or skirt	CG Service Dress slacks or skirt	ODU CG Blue Slacks
Socks / Stockings	Black socks	Black socks	Black socks or flesh tone stockings	Black socks or flesh tone stockings	Black
Shoes	Blue, white or brown boat shoes	Blue, white or brown boat shoes	Black oxfords w/slacks or black dress pumps with skirt	Black oxfords w/slacks or black dress pumps with skirt	Safety boots, low top shoes, or boat shoes***
Gloves	None	None	None	Black (optional)	None
Insignia	Sew on collar devices are authorized	Metal collar devices	Metal collar devices	Enhanced or soft shoulder boards	Sew On Or Metal Collar Devices
Ribbons Medals Breast Device	Sew on coxswain device is authorized - no ribbons	Auxiliary qualification devices - no ribbons	Auxiliary qualification devices - no ribbons	Auxiliary qualification devices - no ribbons	Sew on or Metal Qualification devices
Name Tags	Sew on name tags / USCG Auxiliary tapes	Plastic name tag	Plastic name tag	Plastic name tag	Sew on name tags / USCG Auxiliary tapes
Accessories	Wooly Pully or Cardigan sweater / Black web belt with silver buckle and tip	Wooly Pully or Cardigan sweater / Black web belt with silver buckle and tip	Wooly Pully or Cardigan sweater / Black web belt with silver buckle and tip	Wooly Pully or Cardigan sweater / Black web belt with silver buckle and tip	Black Web Belt with Black Metal Tip Black subdued - open frame buckle
Authorized Outer Garment	Windbreaker, all weather parka, work jacket,	Windbreaker, work jacket, reefer, all weather parka, overcoat, trench coat	Windbreaker, all weather parka, work jacket, reefer, overcoat, trench coat	Windbreaker, all weather parka, work jacket, reefer, overcoat, trench coat	Windbreaker, AWP, Work jacket

* Coast Guard discontinued uniform (08/09/2005). Auxiliarists can wear uniform until unserviceable.

** Can be worn until trousers (Coast Guard Blue Utility) unserviceable. No other trousers can be worn with this uniform at this time.

*** Safety boots, low top shoes (the dress oxford), or boat shoes (dark brown - leather laced) may be prescribed in special cases or for medical reasons.

WOMEN'S AUXILIARY UNIFORMS

Table 2B

	Winter Dress Blue	Tropical Blue	Service Dress Blue - Bravo	Dinner Dress White, Black Jacket
Occasion	In lieu of Service Dress Blue, except where a jacket and tie are appropriate	Authorized all year for meetings, classroom, official functions	Authorized all year for meetings, classroom, official functions	Formal Evening Occasions
Hat	Combination Cap or Garrison Cap	Combination Cap or Garrison Cap	Combination Cap or Garrison Cap	Hat not required - Tiara (optional)
Shirt	CG dark blue - long sleeve	Light blue shirt sleeve shirt with epaulets	Light blue long or short sleeve shirt with epaulets	White Formal
Tie	CG blue 4-in Hand or optional clip-on	None	Blue Tab Tie	Black velvet crescent tie
Coat	None	None	Service Dress CG Blue coat w/ silver buttons	White mess jacket (summer) / Black mess jacket (winter)
Slacks/Skirt	CG Service Dress slacks or skirt	CG Service Dress slacks or skirt	CG Service Dress slacks or skirt	Black floor length or street length skirt
Socks / Stockings	Black socks or flesh tone stockings	Black socks or flesh tone stockings	Black socks or flesh tone stockings	Flesh tone stockings
Shoes	Black oxford w/slacks- black dress pumps w/skirt	Black oxford w/slacks- black dress pumps w/skirt	Black oxford w/slacks- black dress pumps w/skirt	Black Dress Shoes
Gloves	Black (optional)	None	Black (optional)	White
Insignia	metal collar devices	Enhanced or soft shoulder boards	Full sleeve lace on coat & shoulder boards on shirt	Hard shoulder boards/ white jacket; Full sleeve lace/ black jacket
Ribbons Medals Breast Device	Auxiliary qualification devices and Ribbons	Auxiliary qualification devices and Ribbons	Devices and Ribbons on coat	Miniature medals & devices; AUXOP & Past Officer
Name Tags	Plastic name tag	Plastic name tag	Plastic name tag	None
Accessories	Wooly Pully or Cardigan ,all weather parka, sweater, / Black web belt with silver buckle and tip	Wooly Pully or Cardigan sweater/ Black web belt with silver buckle and tip	Black belt with silver buckle and tip	Silver Cummerbund
Authorized Outer Garment	Windbreaker, reefer, trench coat Parka	Windbreaker, reefer, trench coat All Weather Parka	Reefer, trench coat	Trench coat

Note: The Service Dress Alpha Uniform (still authorized for Auxiliary wear at solemn occasions such as funerals and for ceremonies after 6 p.m. at social activities) consists of Service Dress Blue Jacket, Service Dress Blue Skirt, White Long Sleeved shirt, Black Tab Tie, Black Belt, Stockings & Black Dress Pumps. Only the Combination Cap is appropriate for wear with this uniform.

Additional information on Auxiliary uniforms can be found in the Auxiliary Manual COMDTINST M16790.1F

UNIFORM ACCESSORIES

All Weather Parka	The Parka may be worn with or without the zip-in fleece liner with the Working Blue, Undress Blue, Tropical Blue Long, and Winter Dress Blue uniforms. It may also be worn with the Service Dress Blue uniform in place of the Service Dress Coat in the same manner as the Windbreaker when less formality in appearance is appropriate.
Belt	A black web belt with a silver buckle and tip must be worn with all women's slacks and men's trousers, with the exception of the formal Dinner Dress trousers. The buckle may be plain or display an approved Auxiliary emblem. A belt is not worn with the women's skirts.
Gloves	White gloves are made of cotton or other suitable cloth material. Black gloves are made of leather or other synthetic substitute. Glove stitching will match glove color.
Handbags	Women's handbags are black and made of leather or suitable synthetic material. They are plain or embossed with a leather grain and are an envelope style with a detachable shoulder strap. The nominal size is 11" wide by 7 ½" deep.
Scarves	Members may wear the white or dark blue scarf with the reefer, overcoat, or trench coat. The blue scarf may be worn with the undress or working uniforms and all outer garments authorized with those uniforms.
Sweaters	The CG blue Woolly Pully sweater and the Air Force cardigan are both authorized for Auxiliary use. The sweater is not an outer garment for travel purposes. Enhanced or soft shoulder boards are worn on both sweaters.
Undershirts	Men's "V" neck undershirts are required with jumpsuits and all short sleeve shirts with open collars.
Umbrella	A black folding type umbrella is authorized with all Auxiliary uniforms.
Outerwear	Trench coat, reefer, all weather parka, windbreaker.

**PROPER POSITIONING OF COLLAR
INSIGNIAS ON CGAUX UNIFORMS:**

The illustrations below indicate how members should wear collar insignias on the various shirts for which they are authorized. In certain cases, the insignia of current or highest past office is replaced with the Member Device.

- a. Light Blue Shirt and Winter Dress Blue Long Sleeve Shirt: On a closed collar shirt worn with a tie, the collar insignia is placed on collar one inch from the top measured from top of collar device. Device should be set one-inch back and parallel to the inner edge of collar.
- b. Working Blue Short Sleeve Shirt: On an open collar shirt, the insignia is centered on "line" bisecting the angle of the collar point. One and one half inch from collar tip to "A" on insignia, or center of "Member Device".

The Auxiliary does not have RANK, we have INSIGNIA of POSITION, (officer or member).

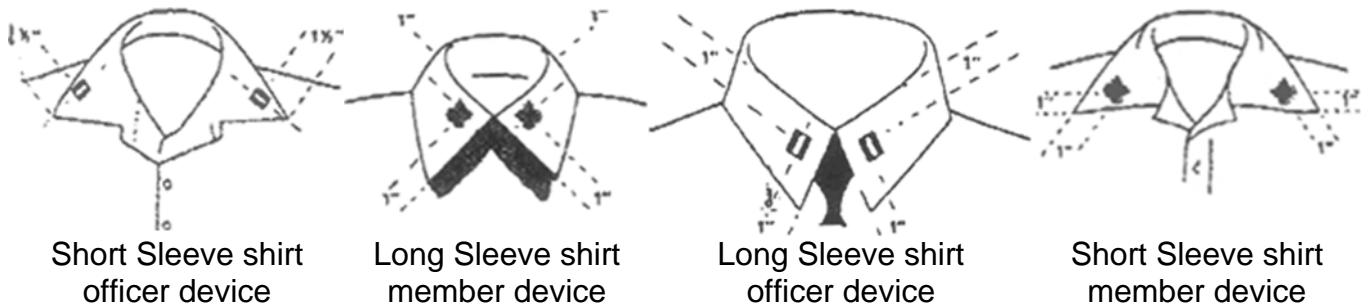

GARRISON CAP:

Members may wear the garrison cap with Flight suit, Service Dress blue, Tropical Blue, Winter Dress Blue or Undress uniforms. The cap may not be worn with the Dinner Dress Blue, Service Dress Blue (Alpha), work, jumpsuit or Blue Blazer uniforms. The small garrison cap insignia (on wearers left forehead) and small metal office insignia, (officer or member on wearers right forehead) are worn on the cap as shown in the diagram with both men's and women's uniforms. The Garrison Cap is UNISEX style.

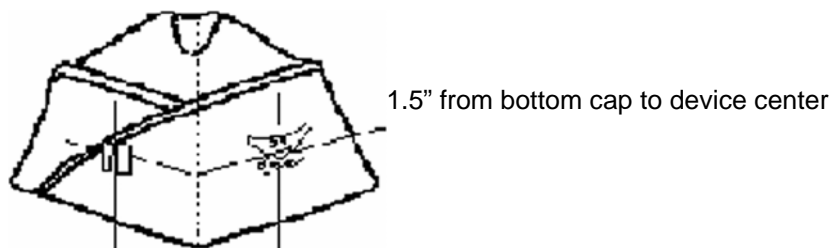

From front of cap to device center is 2.0"

PROPER PLACEMENT OF RIBBONS, NAME TAGS, & QUALIFICATION DEVICES:



The illustration indicates the proper placement of ribbons, the nametag, breast, and qualification devices. As shown, the lowest row of ribbons is $\frac{1}{4}$ inch above the top of the pocket. The first breast device, Coxswain device in this case, is placed $\frac{1}{4}$ inch above the top row of ribbons.

The second breast device, if worn, is placed $\frac{1}{4}$ inch below the top of the pocket. Members wear ribbons, breast devices, and qualification devices on the left side of the uniform. Other branches of the military qualification devices can be worn on left side. Total devices worn on left side is two, this includes Auxiliary and former service qualifications.

On the right side of the uniform, members wear the nametag $\frac{1}{4}$ inch above the pocket. An AUXOP device, if authorized, is worn $\frac{1}{4}$ inch above the nametag. Members wear the past officers' device, if required, $\frac{1}{4}$ inch below the top of the pocket (between buttonhole and stitching). Coast Guard Recruiting Badge, National Staff Identification Badge, are to be worn centered (horizontally and vertically), mid-pocket. The Right side of uniform (any) is for Auxiliary ONLY.

Although the illustration shows a Tropical Blue uniform shirt, members wear these items in the same relative position on the Service Dress Blue coat and the Winter Dress Blue uniform shirt and the Tropical Blue Long shirt, (Air Force Blue short sleeve shirt with Epaulets).

On the Undress and Working Dress shirts, members do not wear ribbons. The first Auxiliary qualification breast device is worn $\frac{1}{4}$ inch above the top of the LEFT pocket. The second is worn $\frac{1}{4}$ inch below the top of the LEFT pocket. The nametag is $\frac{1}{4}$ inch above RIGHT pocket.

BELT AND BUCKLE:

Wear belts with all trousers and skirts that have belt loops.

Item	Description	Related Information
BLACK BELT	The black belt is made of black webbing With an attached silver Clip end (metal tip)	<u>Wear With:</u> -Dress Blue Trousers -Undress Trousers -Working Blue Trousers
SILVER BELT BUCKLE	The standard belt buckle is silver. It is worn with a Black Belt.	<u>Wear With:</u> -Dress Blue Trousers -Undress Trousers -Working Blue Trousers

MANNER OF WEAR FOR STANDARD SILVER BUCKLE:

MEN:

Wear the buckle so that the belt clip end (metal tip) touches the wearer’s LEFT side of the buckle. Align the RIGHT side of the buckle with the opening of the shirt and opening of the fly, forming a straight line, (in the military referred to as a “gig line”).

WOMEN:

Wear the buckle so that the belt clip end (metal tip) touches the wearer’s RIGHT side of the buckle. Align the LEFT side of the buckle with the opening of the shirt forming a straight line. If men’s trousers are worn, align the LEFT side of the buckle with the opening of the shirt and opening of the fly, forming a straight line, (gig line).

The belt should be cut such that there is not a long “tail” left over. In fact, the silver end of the web belt should just slide through your buckle enough so that it appears an uninterrupted chunk of silver at the buckle. No webbing should be exposed between the belt clip and the buckle.

COVERS (HATS):

Hats, or covers, are to be worn squarely on the head, not tilted back or to the side. Hair or bangs should not be visible below the brim or hat line of the cover. Long hair should be up and away from the collar and contained under the hat, not sticking out the back. Covers should always be worn outdoors, and removed indoors. Some Religious Service protocol require cover be worn indoors.

UNIFORM VENDORS:

All apparel obtained from the Uniform Distribution Center (UDC), and government uniform items sold through the Coast Guard Exchange System stores shall be considered regulation uniform items.

UNITED STATES COAST GUARD UNIFORM DISTRIBUTION CENTER

414 Madison Ave
Woodbine, N.J. 08270
Customer Service: (800) 874-6841

GENERAL INFORMATION:

The Coast Guard Uniform Distribution Center (UDC) has a website, <http://www.uscg.mil/uniforms>, which can be publicly accessed by all personnel. This website is recommended as the most efficient means by which members can fulfill their uniform needs.

When on the UDC welcome page, refer to the quick link “Uniform Items.” It is recommended that members peruse the UDC Stock Book and identify both the uniform items desired as well as the corresponding stock numbers. The items listed in the Stock Book are the ONLY items managed by the UDC. A sample UDC Standard Order Form has been provided at the end of this section. Additional copies are available on the UDC “Uniform Items” webpage.

ADVISORY:

Personnel at the UDC suggest that Phone Orders be the primary method when ordering items. This is the most expedient way to fill orders.

HOW TO ORDER:

There are several ways to place uniform orders with the UDC.

- a. Online Orders (NEW)
- b. Phone Orders
- c. Mail Orders
- d. Fax Orders
- e. Government Credit Card Orders
- f. Over-the-Counter Sales
- g. Special Orders

Each option is presented below in accordance with UDC regulations. Supplementary advice from the Uniform Division is printed in CAPITAL LETTERS following the UDC instructions. It is recommended that the UDC website is used simultaneously while reading the following directions.

A. ONLINE ORDERS

Online ordering is now available from the UDC. Click USCG UDC Web Store to gain access. To login for the first time, select “Request/Change Login and Password” and complete the form. An e-mail will be sent to you containing your User Name and Password during normal UDC business hours: 0730 to 1600 (EST), Monday – Friday.

B. PHONE ORDERS

Phone orders may be placed from 0800 to 1530, Monday – Friday, EST. You may use personal MasterCard, Visa, Discover, or American Express credit cards or you may use the Charge-to-Pay method (Coast Guard Active Duty members only). To reduce phone holding time, please have on hand a list of items needed and specific measurements.

To place a Phone Order, call: (800) 874-6841 or (609) 861-1221.

THE AVERAGE PHONE ORDER TAKES APPROXIMATELY 4 TO 5 MINUTES TO PROCESS. IF YOU ARE ON HOLD, BE PATIENT, YOU SHOULD BE SERVED IN 15 MINUTES OR LESS. REMEMBER THAT THE UDC STOP TAKING ORDERS AT 1530 (EST) EVERY DAY. IT IS STRONGLY RECOMMENDED THAT YOU WRITE YOUR ORDER DOWN AND FOLLOW IT WHEN TALKING TO THE UDC.

C. MAIL ORDERS

Uniform orders can be mailed to the UDC by filling out the Standard Order Form available on the website. Include check, money order or credit card information with your order form. If paying by check or money order, please make payable to U.S. Coast Guard for the EXACT AMOUNT of your order. Consult the Stock Book for the correct prices and stock numbers.

Mail your completed order form to:

U.S. Coast Guard
Uniform Distribution Center
ATTN: Customer Service
414 Madison Ave.
Woodbine, N.J. 08270

Remember to sign your Standard Order Form before submitting.

D. FAX ORDERS

Fax orders may be faxed 24 hours a day, 7 days a week. Uniform orders may be faxed to the UDC using the same order form mentioned above. Please FAX your order only ONCE to avoid duplicate orders. If you do not receive your order within seven business days, please contact Customer Service at (800) 874-6841 to check status.

Please fax orders to: (609) 861-7930.

E. GOVERNMENT CREDIT CARD ORDERS

The UDC cannot accept government credit card orders over the phone. These orders must be faxed or mailed on a Procurement Request (form DOT F 4200.1.2CG). Please ensure the Procurement Request includes all of the following information:

- The unit's name
- OPFAC number (Cost center code)
- Ship-To address
- Point of contact with telephone number
- Government credit card account number
- Card expiration date
- Printed name, exactly as it appears on credit card
- Cardholder's signature

F. OVER-THE-COUNTER SALES

The UDC has two locations. Both accept personal MasterCard, Visa, Discover, or American Express credit cards, money orders (for the exact amount of the purchase), or the Charge-to-Pay method (Active-Duty Coast Guard only).

REVIEW THE UDC STOCK BOOK AND IDENTIFY DESIRED ITEMS PRIOR TO YOUR VISIT. CALL AHEAD TO ENSURE THE UDC IS OPEN. IT IS REQUESTED THAT GROUPS OF 4 OR MORE MEMBERS MAKE AN APPOINTMENT WITH THE UDC WHEN PLANNING A VISIT; FITTING SPACE IS LIMITED AND TIME MAY NOT ALLOW FOR VISITS OF THIS MAGNITUDE. PLEASE CALL AHEAD TO MAKE THE NECESSARY ARRANGEMENTS.

Locations:

Woodbine, N.J. – MAIN WAREHOUSE

Over-the-counter sales at the UDC are from 0730 to 1500, Monday – Friday, excluding holidays. Please call (800) 874-6841 or (609) 861-1221 to check availability.

TRACEN, Cape May, N.J.

Due to recruit issues, over-the-counter sales at Training Center Cape May are limited to Thursdays from 0730 to 1500. Depending on recruit issue requirements, times are subject to change without notice. Please call (609) 898-6744 to check availability.

G. SPECIAL ORDERS

If the UDC does not stock a size that you need, you may request that item by completing a special order form. While every order is expedited, the averaged completion time to fill a special order is approximately three months. The order forms are available online. Call (609) 861-7934 for assistance.

IT IS RECOMMENDED THAT YOU OBTAIN THE MEASUREMENT FORMS AVAILABLE AT THE UDC WEBSITE AND BRING THESE WITH YOU TO A LOCAL TAILOR FOR AN ACCURATE MEASUREMENT.

UDC UNIFORM RETURN POLICY:

PLEASE READ THOROUGHLY

Uniform items that are altered in ANY WAY after their receipt are NOT returnable. Uniform items may not normally be returned after 3 months from the date of invoice, even if not worn or altered. Requests to return uniform items after this 3 month period will be reviewed on a case-by-case basis by the UDC. Due to problems with returned items being lost in shipment, members are advised to ship their returns back by requesting a return-receipt confirmation from the shipping source used. The cost of shipping the return back to the UDC is the member's responsibility.

For uniform returns, send your items with a readable copy of your invoice to:

U.S. Coast Guard
Uniform Distribution Center
ATTN: Uniform Returns
414 Madison Ave.
Woodbine, N.J. 08270

If you are shipping back items for an EXCHANGE, please indicate the sizes and quantities you need. You can write this either on the copy of the invoice you include with your return, or on a separate sheet of paper. Please include a phone number where you can be reached and check your shipping address for accuracy. To contact the Returns Department, please call Customer Service at (800) 874-6841.

AUXILIARY ASSISTANCE:

The Uniform Division of the Personnel Department has appointed an AUXILIARY LIASON to the UDC, who stands ready to assist Auxiliary Members in their dealings with the UDC.

CONTACT: Robert J. McHugh, BC-PXL
P.O. Box 113
Kenvil, N.J. 07847
Phone: (973) 229-1487
E-Mail: maxbobby1974@yahoo.com

Please note: E-mail is the preferred method of contact because transactions dealing with stock numbers, sizes, addresses and invoice numbers are better handled by record communication.

Select a Stock Book Category to View

The above link will open the UDC Stock Book in a new window. When you have selected a category and you find the item you want to order, you can minimize the Stock Book page, and return to the form. Please order using the UDC Stock Numbers.

Date:

Do Not Use This Form For Government Credit Cards!

Rate / Rank and Name:

Form of Payment:

- Required

Employee ID (Emplid) or Auxiliary #:

Credit Card #:

- Required

Note: Social Security Numbers are NOT acceptable!

Expiration Date:

Current Status:

Signature:

Contact Information:

Phone - Ext -

Fax-
(for order confirmation)

Home / Unit Address:

Ship to Address (if different):

UDC Stock Number	Qty.	Unit Price	Extended Price	Last name for the name tape or name tag
		\$	\$	
	x		=	
UDC Stock Number	Qty.	Unit Price	Extended Price	Last name for the name tape or name tag
		\$	\$	
	x		=	
UDC Stock Number	Qty.	Unit Price	Extended Price	Last name for the name tape or name tag
		\$	\$	
	x		=	

COAST GUARD, AIR FORCE, NAVY, ARMY EXCHANGE STORES

For locating the State and CGES Regions nearest you, use the web site address:
www.cg-exchange.com

The Coast Guard Exchange system is available for Auxiliarists for the purchase of anything except tobacco and liquor products. It is only at the exchanges of other military services (AAFEES, NEX, etc.) where Auxiliarists are limited to purchasing uniform items. Visiting an Exchange offers the advantage of being able to try on uniform garments to get the correct size. You can take the garments home with you and save shipping costs. To gain entry, Auxiliarists must have their Auxiliary ID Card (USCG-2650A) with them, also to be shown when making a purchase. To assist you in locating an Exchange Supply Store, use the web site above for a directory of all Coast Guard Exchange System Stores, contact the Exchange nearest you for directions. When visiting or ordering from an Exchange for the first time, it is suggested you check on the following:

1. What are the days and hours of operation?
2. What are their return policies?
3. Are checks and/or credit cards accepted?

AUX. UNIFORM ITEMS THAT MAY BE WORN INFORMALLY WHEN NOT ON DUTY:

Only the following uniform items, which do not present a distinctive Coast Guard Auxiliary appearance, may be worn with civilian attire:

- Trench Coat (w/o insignia)
- Windbreaker (w/o insignia)
- All Weather Parka (w/o insignia)
- Sweaters (Cardigan or Woolly-Pully w/o shoulder boards)
- Belts
- Watch Cap
- Ball Cap (w/o insignia)
- Cold Weather Cap (w/o insignia)
- Blue four-in-hand necktie/Bow Ties
- Shoes/Boots
- Gloves
- White Shirts
- The Auxiliary PFD*

* While the PFD is not normally thought of as a uniform item, it may be worn by Auxiliarists when not under orders and not in uniform (per CHDIRAUX and NACO).

U.S. COAST GUARD AUXILIARY CENTER

ST. LOUIS, MO

PHONE: (314) 962-8828

E-Mail: auxcen@sbcglobal.net

The Auxiliary Center (AUXCEN) serves as the business office and warehouse operations facility for the Coast Guard Auxiliary Association (CGAuxA). CGAuxA is the only non-profit corporation authorized by the Commandant of the U.S. Coast Guard to conduct the business affairs for the U.S. Coast Guard Auxiliary National Board.

The AUXCEN provides the materials for all U.S. Coast Guard Auxiliary educational courses through the District Staff Officer for Materials (DSO-MA) in each district. It also provides uniform accessories, flags, pennants, burgees, required Auxiliary operational facilities signage and equipment, and Auxiliary logo items such as caps, shirts, sweaters, jackets, Padfolio, portfolios, watches and many other items. You may also view various items and obtain their stock numbers by visiting the AUXCEN web page at:

<http://www.uscgaux.org/~auxcen/auxcen/>.

The proceeds received from sales of AUXCEN items through your DSO-MA are used to support the various programs of the U.S. Coast Guard Auxiliary including local District programs. Some of the items available from the AUXCEN through your DSO-MA are:

- ▶ Belts & Buckles
- ▶ Enhanced Shoulder Boards (regular/small)
- ▶ Buttons
- ▶ Hard Shoulder Boards (regular/small)
- ▶ Cap Accessories
- ▶ Tilley Hats
- ▶ Combination Caps (members & officers)
- ▶ Comb Cap Frames (members & officers)
- ▶ Garrison Caps
- ▶ Sleeve lace and shields
- ▶ Collar & Coat Insignia
- ▶ Combination Cap Covers
- ▶ Ball Caps
- ▶ VSC Golf-style shirts Cardigan Sweaters
- ▶ Uniform & Social Ties
- ▶ Ribbons/Medals
- ▶ Ribbon/Medal Bars/ Unimounts
- ▶ Ribbon/Medal Attachments
- ▶ Cummerbunds/Cuff Links & Studs
- ▶ Hat Bands (men & women) w/ Cap Device Sewn
- ▶ Hat Bands (men & women)
- ▶ Uniform & Social Name Tags
- ▶ Blazer Patches
- ▶ Coxswain/Aviation-Air Crew Devices
- ▶ Past Officer and AUXOP Devices
- ▶ Marine Safety Trident Devices (Metal)
- ▶ PWC Operators Device (Metal)
- ▶ To request an OPS Polo Shirt form, contact auxcen@sbcglobal.net.

**USCG AUXILIARY TUNIC OVERBLOUSE
UNIFORM OPTION FOR ALL WOMEN**

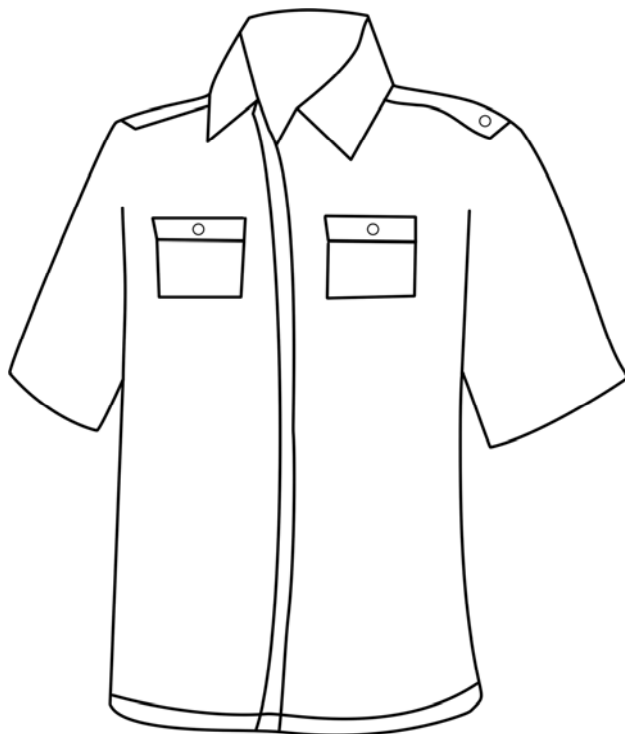

The qualification insignia, shoulder boards, ribbons, etc. that are worn with the tropical blue long uniform shirt can be worn on this shirt.

SIZE CHART

Size	Collar	Bust	Waist	Shoulder	Back Length
22	16	54	52 ½	19 ¾	30
24	16	56	54 ½	20	30
26	16 ½	58	56 ½	20 ½	30
28	17	60	58 ½	21	30
30	17 ½	62	60 ½	21 ½	30



Supporting *America's Volunteer Lifesavers®*

PRINT CLEARLY ALL ENTRIES BELOW

Name & Address of person purchasing order:
 (If street address not indicated below then insert in ship to address)

Ship to address:
 (Must contain street address for shipping items)

Name **(For credit card purchases, must be as appears on card)**

Name

Address/POB

c/o

City, State, Zip Code

Street Address w Apt. No.

Phone: Day _____ Home Business
 Phone: Evening _____ Home Business

City, State, Zip Code

Dist. -Region/Div./Flot. No. (REQUIRED): |_____/_____/_____

Nat'l Staff Mbrs insert office: _____

E-mail address: _____

Deliver Telephone: _____

Item No:	Quantity:	Description:	Cost:	Total:

NOTE: QUANTITIES LIMITED ON CERTAIN ITEMS – NO BACK ORDERS

Method of Payment:

MasterCard VISA Check or Money Order (No cash)
 Payable to: **CGAuxA, Inc.**

Expiration Date: _____ Validation No: _____
 MO YR. (required – last 3-digits number near signature block
 Reverse side of credit card)

Total of Order: _____
 Shipping Costs: _____
 FEDEX Costs: _____
 (if applicable)
 TOTAL AMOUNT Due: _____

Signature: _____
 Order by MAIL TO:

Coast Guard Auxiliary Center
 9449 Watson Industrial Park
 St. Louis, MO 63126-1522
 Credit Card Order by FAX TO: (314) 962-6804
 11/03

Add Addt'l \$8 for FEDEX 2-day
 (HI/AK/PR/GU shipped USPS;
 add Addt'l \$18 for FEDEX)

Shipping Chart:

Order Value	Rate
Up to \$25	\$4.50
\$25.01 to \$75	\$6.95
\$75.01 to \$125	\$8.95
\$125.01 to \$150	\$10.95
Over \$150	\$11.95

U.S. NAVY UNIFORM SUPPORT CENTER

1545 CROSSWAYS BLVD.

CHESAPEAKE, VA 23320

PHONE: 1-800-368-4088

E-Mail: uscgovt@hq.nex.net.com

PHONE ORDERS ONLY. Charge to MasterCard, VISA, Discover or AMEX. No Mail Orders. UNIFORM GARMENTS AVAILABLE. Express shipping available. Prices are subject to change without notice. Inquire when ordering.

MEN'S DINNER DRESS WHITE JACKET, 36-52, S-R-T-XT	\$137.00
MEN'S DINNER DRESS NAVY BLUE JACKET, 35-52, S-R-T-XT	\$155.00
MEN'S DINNER DRESS NAVY BLUE TGROUSERS, 28-48, S-R-T-XT	\$ 59.00
MEN'S REEFER COAT, 32R-52XL - PLUS COST OF BUTTONS (\$1.70 EA)	\$134.05
WOMEN'S REEFER COAT, 6R-2XL - PLUS COST OF BUTTONS (\$1.70 EA)	\$128.30
WOMEN'S DINNER DRESS WHITE JACKET, SP4-28WT	\$147.00
WOMEN'S DINNER DRESS SHIRT (PLEATED W/TIE), LS, UP TO 46X34	\$ 34.00
CUFF LINKS (BRUSHED SILVER) FOR ABOVE DRESS SHIRT (will need two pairs)	\$ 5.00
STUDS (BLACK) FOR ABOVE DRESS SHIRT (will need two pairs)	\$ 9.09
WOMEN'S DINNER DRESS SKIRT (LONG) 4-24 WR	\$ 90.00
WOMEN'S SERV. DRESS WHITE SHIRT, SMALL SIZE	\$ 25.50
WOMEN'S SERV. DRESS WHITE SHIRT, LARGE SIZE	\$ 27.00

The U.S. Naval Support Center presently provides uniforms to retired Coast Guard, Active Duty and Reserve only. This pricing information is included for Auxiliary members who meet this criterion. All Auxiliaries can continue to order their formal uniforms from the U.S. Navy Uniform Support Center. Auxiliaries are not granted access to NEX web site, it is a Department of Defense directive.

U.S. COAST GUARD ACADEMY CLOTHING LOCKER

15 MOHEGAN AVENUE

NEW LONDON, CT 06320-4195

PHONE: (860) 444-8300

Walk in only. No mail orders at this time. VISA and MasterCard are accepted. There is both an Exchange and the Cadet Uniform Store. The Exchange has USED but still serviceable uniforms at ½ price. The Uniform Store is in the north end of Chase Hall and is only open during the week. The Exchange is in Johnson Hall and does have some Auxiliary items. The size/selection is geared toward the aspiring Coast Guard officer candidate. If you are near military weight, you will find plenty of good items.

Hours:

Monday/Tuesday & Thursday: 0900-1530

Wednesday & Friday: 0900-1130

KINGFORM CAP COMPANY INC.

184-08 JAMAICA AVENUE
 HOLLIS, NY 11423
PHONE: (718) 776-7070
FAX: (718) 776-6826
E-Mail: Lenny@Kingform.Cap.com

WOMEN'S COMBINATION HAT
 ORDERS ARE PLACED BY MAIL USING FORM BELOW. (DO NOT USE P.O. BOX)

NAME: _____

ADDRESS: _____

CITY: _____ STATE: _____ ZIP: _____

PHONE: _____ DATE: _____

Enclosed is a check for \$_____ Payable to Kingform Cap Company, Inc.
 Enclosed is a Money Order for \$_____ Payable to Kingform Cap Company

Charge to my: Master Card Visa

Card number: _____

Expiration date: _____

X _____
 Signature (as shown on credit card)

STOCK #	DESCRIPTION	PRICE	QTY.	TOTAL
#33632	Officer's Combination Hat With White Vinyl cover, Blue Hat Band, Officer Insignia Mount, Silver Auxiliary Buttons. No Embroidery. Size:	\$70.00		
SHIPPING & HANDLING		\$12.95		
#33634	Officer's Combination Hat With White Vinyl cover, Embroidered Blue Hat Band With Single Row Of Oak Leaves And Acorns and Cap Insignia. The Top Of The Band Will Be Edged With Silver Braid. Size:	\$105.00		
SHIPPING & HANDLING		\$12.95		
#33635	Officer's Combination Hat With White Vinyl cover, Embroidered Blue Hat Band With Double Row Of Oak Leaves And Acorns And Band Will Be Edged With Size:	\$120.00		
SHIPPING & HANDLING		\$12.95		
#1700	White Vinyl Hat Cover Size:	\$12.00		
SHIPPING & HANDLING		\$9.95		
TOTAL:				

Prices can change without notice. Inquire when placing order.

Note: One row oak leaves and acorns for VCO, RCO, DCP, DC, and DVC. Two rows oak leaves and acorns for NACO, NAVCO, NARCO AND DCO

LIGHTHOUSE UNIFORM COMPANY

1532 15TH AVENUE WEST
PO BOX 19213
SEATTLE, WA 98119

PHONE: 1-800-426-5225
FAX: (206) 282-5662
E-Mail: Light@LighthouseUniform.com

An appreciative thank you to the Coast Guard Auxiliary for this opportunity to participate in its uniform and accessory procurement process and also an invitation to visit and utilize our Coast Guard Auxiliary web page. Get there by going to your National Board Inc.'s Web site and clicking over via the Lighthouse link.

HOW TO ORDER:

Use the toll free number when ordering. They've included an Order Form for you to use. The easiest way to order is to fill out the attached order form then read it when you call them. They will accept MasterCard, Visa, Discover and American Express credit cards. Your order will be processed and shipped via UPS and Airborne. They also offer express delivery via UPS Next Day Air, 2nd Day Air, and 3rd Day Select. All packages are insured.

You can also visit their Website at www.lighthouseuniform.com. Lighthouse Uniform Company is a full service uniform store for men in the U.S. Coast Guard Auxiliary. They specialize in oversize uniform items and do carry some things for women in the Auxiliary including the new women's service dress blue jacket. Lighthouse now stocks the ODU uniforms for men and women. They are, however, military seconds with a very slight color variance in shade. In addition, they have a restriping service available for men and women plus carry a full line of Military Large Medals, Miniature Medals, and Ribbons. They have been providing service to the U.S.C.G. Auxiliary for the last 35 years. They have four in-house tailors to make your uniform fit correctly.

PRICING:

We believe these prices to be accurate. Prices are subject to change without notice.

Uniform, Men's Dinner Dress Blue - 55% poly 45% wool Tropical Worsted, includes Coat with Auxiliary Buttons and High Waisted Trousers (call us for striping cost)	
Sizes 36 to 46	\$289.95
Sizes 48 to 54	Call for pricing
Uniform, Men's Mess Jacket, White - CNT, lined, with Auxiliary Buttons	
Sizes 36 to 46	\$189.95
Sizes 48 to 54	Call for pricing
Trousers, Men's High-Waisted, Black - 55% poly 45% wool Tropical Worsted	
Sizes 30 to 42	\$79.95
Sizes 44 to 50	\$99.95
Uniform, Men's Bravo - (The Davis Model) Tropical Worsted (call for striping cost)	
Sizes 36 to 46	\$289.95
Sizes 48 to 54	Call for pricing

(Continued)

Trousers, Men's Bravo - (The Davis Model) Tropical Worsted. Hemming included	
Sizes 30 to 42	\$69.95
Sizes 44 to 50	\$87.45
Shirts, Men's and Women's - Light Blue is with Epaulets	
Men's Sizes 14½ to 17½.....	Short SleeveLong Sleeve \$28.95 \$ 29.95
Men's Sizes 18 to 20.....	\$48.95 \$ 49.95
Women's Sizes:	Call for prices... Call for prices
Shirts, Men - Dark Blue, Long Sleeve, CIAO Style with Epaulets	
Men's Sizes 15 to 17½.....	\$ 39.95
Men's Sizes 18 to 20.....	\$ 49.95
Shirts, Tuxedo, Men's, White, Long Sleeve	
Sizes 14½ to 17½	\$ 29.95
Sizes 18 to 22	\$ 37.50
Cummerbund, Silver, adjustable.....	
	\$ 19.95
Jumpsuit, Men's or Women's, will Auxiliary Patch	
Sizes Small to X-large.....	\$ 29.95
Size XX-large	\$ 37.50
Coveralls, Men's with Auxiliary Patch	
Sizes 36 to 46, Regular or Tall	\$ 29.95
Sizes 48 to 58, Regular or Tall	\$ 37.50
Sweater, Woolly Pulley, Coast Guard Blue, 100% Wool	
Sizes 36 to 46	\$ 59.95
Sizes 48 to 52	\$ 74.95
Blazers, Men's and Women's - 100% poly, includes Auxiliary Buttons and Auxiliary Member Patch	
Men's and Women's	\$119.95
Men and Women's (Poly/Wool)	\$139.95
Trousers, Men's and Women's Grey, 100% poly, machine washable	
Men's Sizes 30 to 42.....	\$ 39.95
Men's Sizes 44 to 50.....	\$ 49.95
Women's sizes 8 to 18.....	\$ 39.95
Women's Sizes 20 to 24	\$ 49.95

	NACO	NAVC	DC	DVC	BC	AIDE	DCO	VCO	RCO	DSO	DCP	VCP	SO	FC	VFC	FSO
COLLAR PINS	14.95	14.95	10.95	10.95	10.95	10.95	10.95	10.95	10.95	10.95	10.95	10.95	10.95	10.95	10.95	10.95
SHOULDER BOARDS	54.95	49.95	34.95	32.95	32.95	30.95	49.95	34.95	34.95	32.95	32.95	32.95	30.95	30.95	30.95	28.95
SLEEVE STRIPING	40.95	38.95	32.95	30.95	30.95	29.95	36.95	32.95	32.95	30.95	30.95	30.95	29.95	29.95	29.95	28.95
RAINCOAT PINS	16.95	14.95	12.95	12.95	12.95	12.95	12.95	12.95	12.95	12.95	12.95	12.95	12.95	12.95	12.95	12.95
SOFT BOARDS	44.95	39.95	24.95	22.95	22.95	20.95	39.95	34.95	24.95	22.95	22.95	22.95	20.95	20.95	20.95	18.95
ENHANCED BOARDS	49.95	44.95	29.95	27.95	27.95	25.95	44.95	29.95	24.95	27.95	27.95	27.95	25.95	25.95	25.95	22.95

Lighthouse Uniform Company

Order Form

Ordered by:

Name _____ Rank: _____

Address _____

City _____

State _____

Zip _____

Phone (____) _____ Date: _____

Ship to: (Only if different from Ordered by:)

Name _____ Rank: _____

Address _____

City _____

State _____

Zip _____

Phone (____) _____ Date: _____

Quantity	Item No. / Description	Size	Price Ea.	Total
Method of Payment:			Total Price of items:	
			Delivery in WA add 8.2% Sales Tax:	
			Shipping, Packing, Handling and Insurance:	
			Total:	

Check or Money Order enclosed

Charge to my: Master Card Visa American Express

ORDER TOLL FREE: 1-800-426-5225

For faster order placement fill out order form,
then call us toll-free with your order.

Card number: _____

Expiration date: _____

X _____
Signature (as shown on credit card)

PROPPER INTERNATIONAL

520 HUBER PARK COURT
ST. CHARLES, MO 63304

TOLL FREE: (800) 296-9690

FAX: (877) 296-9690

PHONE: (636) 685-1000

The All Weather Parka is approved as an optional outer garment for foul and cold weather. It was tested under extreme weather conditions in afloat and ashore operational environments. It is of an upper thigh length with a CG Blue Laminated supplex nylon and core-tex outer waterproof shell with foldaway hood and a wind stopping polar-fleece zip-in Liner. It is rated for use in temperatures down to 0 degrees Fahrenheit. The All Weather Parka will be approved for wear with many Coast Guard Auxiliary uniform ensembles, except with uniforms and during occasions where more formality is required. It may be worn with or without the zip-in liner.

The AWP is sold under the description, Foul Weather Parka, Model #F5406: \$ 166.94
The Zip-in Front Polartec Jacket Liner, Model # F5412: \$ 40.72
Foul Weather Trouser, Model # F5206: \$ 112.20
Sizes: S, M, L, XL, XXL

As of 10/06/06, Type I AWP is still available (and authorized), but has been removed from GSA. Only limited sizes/quantities remain. Type II is the go-forward model for the USCG, and has replaced the Type I on GSA. See page 27.

ALL WEATHER PARKA I

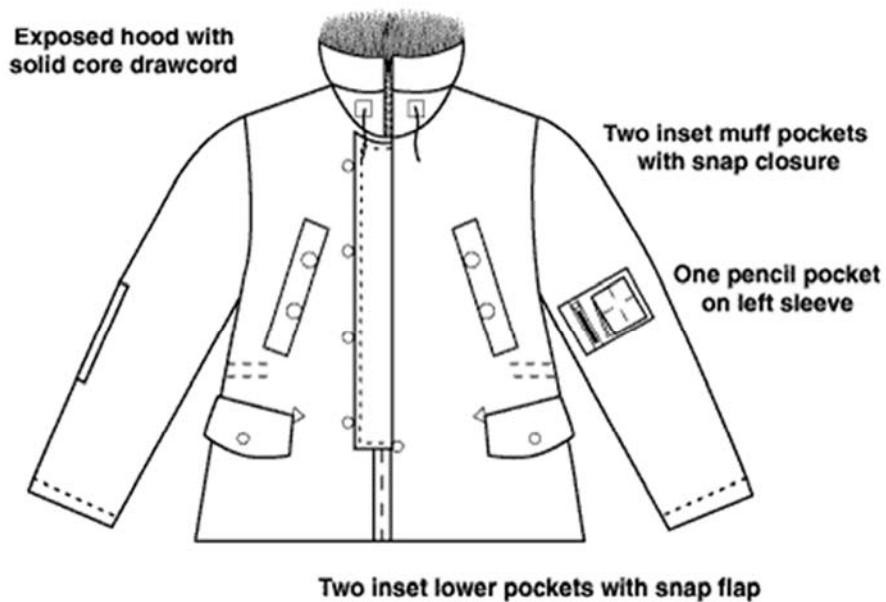

Smaller Collar insignia is worn centered on rank tab on front of Parka.

NEW ALL WEATHER II OUTERWEAR SYSTEM

AVAILABLE JULY 2006

1. The NEW ALL WEATHER PARKA II (AWP II) Outerwear system is now available for USCG and USCG AUXILIARY personnel. This new system is the improved version of the AWP outerwear system and includes added features and additional sizes/lengths for Active Duty and Auxiliary personnel.

AWP II = 35 Sizes

AWP II Fleece Liner = 35 Sizes

AWP II Trouser = 33 Sizes

2. The AWP I and AWP II systems are authorized for use by Active Duty and Auxiliary personnel. Ref. AWP information ALCOAST 489/02 bulletin for USCG guidelines on the wear of the Type II system.
3. Orders may placed by phone or fax. Orders will require a major credit card, and will shipped ONLY to a military address, a MSO, Station, Sector etc. The AWP I or II will NOT be delivered to a PRIVATE HOME. Faxed orders may use Receipt For Clothing And Small Stores Form CG 3019 (Rev. 6-04), see following page. Units may also order via the GSAWebsite (use key words "foul weather"). ALCOAST 489/02 refers.
4. The AWP II components are sold under the following style number descriptions:

Style #	Description	GSA Price
F 5407	Foul Weather II Parka	\$ 181.67
F 5413	Foul Weather II Fleece Liner	\$ 42.30
F 5207	Foul Weather II Trouser	\$ 131.75

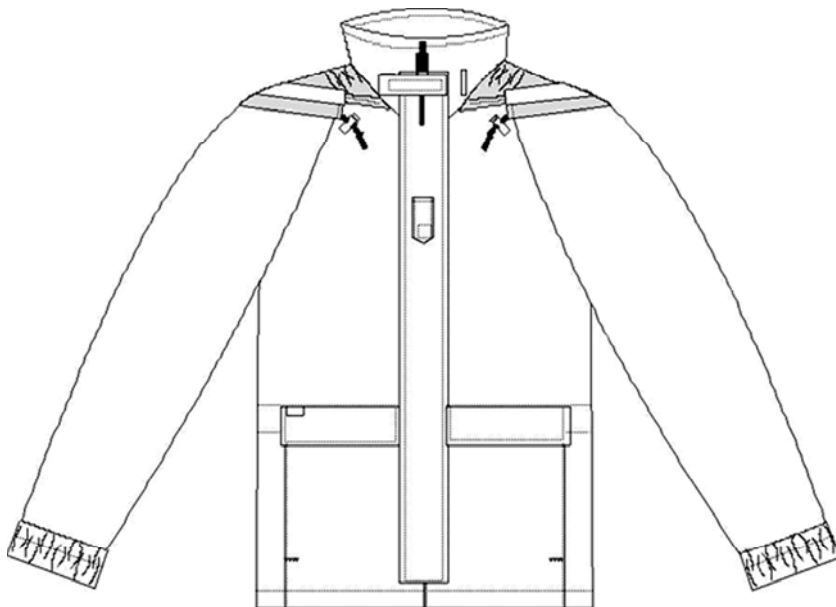

For additional information contact Propper International 520 Huber Park Court
St.Charles, MO. 63304 Phone: 636-685-1081 E-mail: fwp@propper.com

***SPECIFY SIZE. ALL ITEMS COME IN A WIDE RANGE OF SIZES, STARTING AT XS WITH XS LENGTH AND UP. IF YOU NEED ANY FURTHER ASSISTANCE, PLEASE CALL, 1-800-296-9690. THANK YOU.**

****Complete blocks marked with an X. Fax to 1-877-296-9690**

U.S. DEPARTMENT OF HOMELAND SECURITY U.S. COAST GUARD CD-3019 (Rev. 6-04)					RECEIPT FOR CLOTHING AND SMALL STORES					DATE X				
NAME X					SERVICE NUMBER		SOCIAL SECURITY NUMBER		GRADE/RATE					
UNIT X					SUPPLY ACTIVITY									
ARTICLE	SIZE	QUANTITY	UNIT PRICE	EXTENSION	ARTICLE	SIZE	QUANTITY	UNIT PRICE	EXTENSION					
BADGE, RAT. RED				0.00	SHIRT, UTILITY				0.00					
BAG, DUFFEL				0.00	SHIRT, WH. LS.				0.00					
BELT, BLK.				0.00	SHIRT, LT. BL. SS.				0.00					
BUCKLE, BELT				0.00	SHIRT, LT. BL. LS.				0.00					
					SHOES, GYM				0.00					
CAP, GARRISON				0.00	SHOES, DRESS BLK.				0.00					
CAP, UTILITY				0.00	SHOES, SAFETY				0.00					
COAST, SER. DRESS				0.00	SOCKS, COT. BLK.				0.00					
CROWN, SER. CAP				0.00	STRAP, CHIN				0.00					
					STRIPES, SER. RED				0.00					
DEVICES, COLLAR				0.00										
DRAWERS, COT.				0.00	TOWEL, BATH, LG.				0.00					
					TROUSERS, UTILITY				0.00					
GLOVES, WHITE				0.00	TROUSERS, UNDRRESS CG. BL.				0.00					
GLOVES, BLK. LTHR.				0.00	TROUSERS, SER. DR.				0.00					
					TRUNKS, SWIM				0.00					
FRAMES, CAP				0.00										
					SPECIFY SIZE									
INSIGNIA, GAR. CAP				0.00	Foul Weather			\$131.75	0.00					
INSIGNIA, DR. CAP				0.00	Trouser II									
INSIGNIA, BR/SER.				0.00	F5207									
JACKET, UTILITY				0.00	Foul Weather			\$181.67	0.00					
					Parka II									
MARK, GROUP RATE				0.00	F5407									
MOUNT, CAP W/BD				0.00										
					Parka Liner			\$42.30	0.00					
NECKTIE, BL.				0.00	II									
					F5413									
RAINCOAT, BL., WL				0.00										
TYPE OF DOCUMENTATION (Check applicable box(es))					GSA Schedule: GS-07F-0228M					TOTAL				
<input type="checkbox"/> MAIL ORDER SERVICE					<input type="checkbox"/> UNIT REQUISITION					<input type="checkbox"/> REIMBURSEMENT FOR LOSS				
<input type="checkbox"/> INVENTORY LISTING					<input type="checkbox"/> BULK STOCK BREAKOUT					<input type="checkbox"/> HEALTH AND COMFORT ISSUE				
<input type="checkbox"/> INITIAL ALLOWANCE					<input type="checkbox"/> CASH SALE					<input type="checkbox"/> CHARGE TO PAY				
<input checked="" type="checkbox"/> OTHER (Specify)					Credit Card #:					Expires:				
SHIPPING ADDRESS					CERTIFICATE					SIGNATURE				
X					RECEIPT of above items is hereby acknowledged									
PAY RE CORD CHECKAGE					INVENTORY listed hereon certified correct.									
UNIT					DATE					MAIL ORDER service requested;				
X					X					payment attached \$				
The amount hereon has been charged to the pay record of the individual concerned.					Signature X									
Phone:					MEMORANDA (Shipping data, special instructions, etc.)									
Fax #:														
Email:														

ULTRA THIN RIBBONS & MEDALS

P.O. BOX 7161

MOORE, OK 73153

PHONE: 1-800-758-7265

HOW TO ORDER:

There are four ways to place your order: Toll free Phone, by Mail, by Toll free Fax or by E-MAIL. Fax number is: 1-800-962-1451. The email address is: UltraThin@aol.com. They will accept VISA, MasterCard, American Express & Discover credit cards. Checks accepted but no COD shipments. To obtain a copy of order form/price list call toll free: 1-800-758-7265 or order on line at <http://www.ultrathin.com/>.

MAGNETIC RIBBONS:

Ultra Thin magnetics allow you to attach ribbons to your shirt without poking holes. Put them on or take them off as many times as you wish with no tell tale holes left in the shirt. Magnetics are not for use on the Service Dress Coat due to the increased fabric thickness. To order, check the box for magnetic fastener and add \$3.00 in the Additional Services block.

To obtain a copy of order form/price list call toll free: 1-800-758-7265 or order on line at:
<http://www.ultrathin.com/>

SEW ON UNIFORM INSIGNIA

AUTHORIZED COMPANIES

Vendors selling uniform items such as nametapes and insignia have provided samples that were found to be acceptable. Cloth nametapes and collar devices can be sewn on the Dark Blue Working Uniforms, the Operational Dress Uniform and the Auxiliary Jumpsuit. The sew-on Coxswain insignia is approved for wear on the Working Blue and ODU Uniform. You can obtain the sew-on devices from the same vendors that are listed for the collar insignia as well as other sources that supply CG bases and training centers. Sew-on insignia may be used on the Dark Blue Auxiliary Base Ball Cap that has the letters U.S.C.G. arched over "Auxiliary", (Auxiliary Manual COMDTINST M 16790 .1F Chapter 10, pg.15, para. D.3.b). All queries regarding items, (deliveries, quality of), should be addressed to the DVC-PX Uniforms, who will be pleased to address them at pelagic200@aol.com.

<u>The Bent Needle</u> 1444 Commercial Street Astoria, OR 97103 (503) 325-0638 E-Mail: www.bentneedle.net	Name tapes	\$1.75 each
	Collar devices	\$5.00 pair
	Coxswain device	\$3.50 one
	Plus shipping	\$2.00
	MC/VISA/Check	

<u>DeeBee's Tailoring & Cleaners</u> USCG SUPTCEN P.O. Box 5041 Coast Guard Island Alameda, CA 94501-5100 (510) 536-4252 E-Mail: www.dbtailor@hotmail.com	Name tapes	\$2.95 each
	Collar devices	\$4.95 pair
	Coxswain device	\$3.95 one
	Plus shipping	\$1.95
	MC/VISA/Check	

<u>Uniform Name Tape Company</u> 6807 MacDill Ave. Tampa, FL 33611 (813) 839-6737 1-800-237-0011 (outside Florida)	Name tapes	\$1.50 each
	Collar devices	\$2.00 pair
	Coxswain device	\$2.00 one
	Plus shipping	\$3.00
	MC/VISA/AMEX/Check	

<u>Wings and Things</u> 3815 Navy Blvd. Pensacola, FL 32507 (850) 455-3081 E-Mail:www.wingthings@aol.com	Name tapes	\$1.50 each
	Collar devices	\$2.00 pair
	Coxswain device	\$2.00 one
	Plus shipping	
	MC/VISA/AMEX/DISC Check	

HOW TO ORDER:

Phone orders are accepted from the companies listed above. Member collar devices are available as well as officer devices. All accept the credit cards listed. Member collar devices are available as well as officer devices. One word of caution, however, anyone sewing on officer collar devices may have to change them or wear an alternate shirt if they crew on a Coast Guard vessel or with Coast Guard Aviation. In that case, all that should be worn are member devices so as not to confuse the active duty Coast Guard personnel with a two star (Auxiliary) taking orders from a third class (active duty Coast Guard). It is suggested that, when ordering name tapes, you provide the vendor with the width of your shirt pocket to ensure that the name tapes sent will extend to the edges of the pocket (but not beyond) when it is sewn on. You should have enough material to turn the edges under before sewing the nametapes on your uniform. If the edges are not sewn under, they will fray when washed. When ordering your collar devices, be sure to indicate whether you need blue "A" (elected) or red "A" (appointed). For the safety members participating in operations missions, be sure to wear the sew-on cloth tapes when wearing a personal flotation device (PFD), as the regular name tags and insignia can easily become snagged on the mesh liner and cause injury to the wearer.

THE BENT NEEDLE
 1444 COMMERCIAL STREET
 ASTORIA, OR 97103
 Prices may change without notice.

NAME: _____
 ADDRESS: _____
 CITY: _____ STATE: _____ ZIP: _____

ITEM:	QUANTITY	PRICE	TOTAL
U.S.C.G. AUXILIARY TAPE:		\$1.75	
NAME TAPE:		\$1.75	
SEW ON MEMBER DEVICE:		\$5.00	
SEW ON COXSWAIN DEVICE:		\$3.50	
SHIPPING:		\$2.00	
TOTAL AMOUNT ENCLOSED:			

STICED IN THE U.S.A.

VISA OR MASTER CARD ACCEPTED WITH PURCHASE OF \$15.00 OR MORE.

Charge to my: Master Card Visa

Card number: _____

Expiration date: _____

X _____
 Signature (as shown on credit card)

DEE BEE'S TAILOR & CLEANERS

U.S.C.G. SUPPORT CENTER
P.O. BOX 5041
COAST GUARD ISLAND
ALAMEDA, CA 94501-5100
PHONE: (510) 536-4252 * 437-3726
FAX: (510) 536-4252
PHONE ORDERS ARE WELCOME

NAME: _____
ADDRESS: _____
CITY: _____ STATE: _____ ZIP: _____

ITEM:	QUANTITY	PRICE	TOTAL
U.S.C.G. AUXILIARY (CLOTH)		\$2.95	
U.S.C.G. AUXILIARY COXSWAINS (CLOTH)		\$3.95	
U.S.C.G. AUXILIARY COLLAR DEVICES (CLOTH)		\$4.95	
SHIPPING & HANDLING		\$1.95	
CALIFORNIA SALES TAX		8.25%	
TOTAL AMOUNT ENCLOSED:			

YOUR OFFICE/POSITION: _____

UNIFORM TAPE COMPANY U.S.C.G. AUXILIARY SEW-ON INSIGNIA ORDER FORM

6807 S MacDill Avenue
Tampa, Florida 33611

NAME: _____

ADDRESS: _____

CITY: _____ STATE: _____ ZIP: _____

PHONE: _____ DATE: _____

DESCRIPTION	PRICE	QUANTITY	TOTAL
COXSWAIN DEVICE	\$2.00 SET		
MEMBER COLLAR INSIGNIA	\$2.00 SET		
SINGLE BAR W/A:			
FLOTILLA STAFF OFFICER GOLD/RED	\$2.00 SET		
VICE FLOTILLA COMMANDER SILVER/BLUE	\$2.00 SET		
DOUBLE BAR W/A:			
ASSIST.DIST.STAFF OFFICER SILVER/RED	\$2.00 SET		
DIST.COMMODORE AID SILVER/RED	\$2.00 SET		
BRANCH ASSISTANT SILVER/RED	\$2.00 SET		
LEAF W/A:			
VICE CAPTAIN GOLD/BLUE	\$2.00 SET		
DIVISION CAPTAIN SILVER/BLUE	\$2.00 SET		
DIST STAFF OFFICER GOLD/RED	\$2.00 SET		
BRANCH CHIEF GOLD/RED	\$2.00 SET		
DIVISION CHIEF SILVER/RED	\$2.00 SET		
EAGLES W/A:			
VICE COMMODORE SILVER/BLUE	\$2.00 SET		
REAR COMMODORE SILVER/BLUE	\$2.00 SET		
DEPARTMENT CHIEF SILVER/RED	\$2.00 SET		
NAT'L COMMODORE'S AIDE SILVER/RED	\$2.00 SET		
STAR (S) W/A:			
DISTRICT COMMODORE 1 SILVER / 1 SMALL BLUE	\$2.00 SET		
NAT'L VICE COMMODORE 2 SILVER / 1 LARGE BLUE	\$2.00 SET		
NAT'L COMMODORE 3 SILVER / 1 SMALL BLUE	\$2.00 SET		
TAPES:			
U.S.C.G AUXILIARY	\$1.00 EA		
NAMES:	\$1.50 EA		
PLASTIC TAG:			
WHITE W/BUE LETTERS			
NAMES:	\$4.50 EA		
SUB TOTAL:			
FL RESIDENTS 6.75% TAX:			
SHIPPING UP TO 50 PCS:			\$3.00
TOTAL:			

Charge to my: Master Card Visa American Express

Card number: _____

Expiration date: _____

X _____

Signature (as shown on credit card)

(813) 839- 6737 (800) 237-0011 Fax (813) 839-6001

WINGS and THINGS MONOGRAMMING

3815 Navy Blvd.
 Pensacola, FL 32507
PHONE: (850) 455-3081
FAX: 850-453-0092 Silver

Ordered by:

Ship to: (Only if different from Ordered by:)

Name _____ Date: _____
 Address _____
 City _____
 State _____
 Zip _____
 Phone (____) _____

Name _____ Date: _____
 Address _____
 City _____
 State _____
 Zip _____
 Phone (____) _____

Product	Description	Price	Qty	Total
Coxswain Device	Bronze Emblem	\$2.00		
Aircrew Wings	Sew-On-Wings	\$2.00		
Member Device	Crossed Anchors-Gold and Blue Inside Shied in Center	\$2.00		
Member Collar Insignia	Crossed Anchors-Gold and Blue Inside	\$2.00		
Flotilla Staff Officer	Collar-Shoulder 1 Gold Bar With Red A	\$2.00		
Vice Flotilla Commander	Collar-Shoulder 1 Silver Bar With Blue A	\$2.00		
Division Staff Officer	Collar-Shoulder 1 Silver Bar With Red A	\$2.00		
Flotilla Commander	Collar-Shoulder 2 Silver Bars With Blue A	\$2.00		
Asst. District Staff Officer	Collar Shoulder 2 Silver Bars With Red A	\$2.00		
Vice Captain	Collar-Shoulder Gold Leaf With Blue A	\$2.00		
Division Captain	Collar-Shoulder Silver Leaf With Blue A	\$2.00		
District Staff	Collar-Shoulder Gold Leaf With Red A	\$2.00		
Division Chief	Collar-Shoulder Silver Leaf With Red A	\$2.00		
Vice Commodore	Collar-Shoulder Silver Eagle With Blue A	\$2.00		
Department Chief	Collar-Shoulder Silver Eagle With Red A	\$2.00		
USCGAUX Aviator	Silver Wings With Shield	\$2.00		
Auxiliary Operation (AUXOP)	Crossed Anchors,Gold and Blue Inside Circled BY Wreath	\$2.00		
USCG Auxiliary	Webbing Strip With Embroidery	\$1.50		
Namestrips	Webbing Strip With Embroidery	\$1.50		
Sub Total:				
Sales Tax 7.5%:				
Shipping:				
Grand Total:				

Pay Method: Check Money Order
 Master Card Visa Discover

Card number: _____

Expiration date: _____

X _____
 Signature (as shown on credit card)

CARE AND MAINTENANCE OF AUXILIARY UNIFORMS

Uniforms are a big investment, and with conscientious care, they can truly last for years and can be a pleasure to wear. The best way to make uniforms last and keep them looking sharp is to give them proper care. Keep them cleaned, and on hangers when possible. No matter how well a new uniform fits, it will soon lose its shape - especially the coat - if the pockets bulge with odds and ends. Trousers should never be tossed over a chair but hung to keep the press in. Use hangers specially made for pants. And hang them with empty pockets and no belt. As a rule of thumb, clean your tailored trousers every second or third wearing. More casual pants (cotton) could use a more frequent cleaning. Brush them in between cleanings. We recommend turning cotton trousers inside out before washing and drying to cut down on undue abrasion. Damp clothing should be carefully hung and smoothed out to avoid wrinkles as it dries.

SILVER LACE, CAP DEVICES AND BUTTONS

Silver lace, or braid, will tarnish and is best cleaned by an experienced tailor. However, most uniform shops sell a commercial cleaner that will remove light tarnish. Embroidered cap devices and other insignia may be kept bright by light brushing with a small brush and ammonia diluted in water. This should be done at the first signs of tarnish. After heavy discoloration, the device cannot be restored to its original condition.

Metal cap devices can be kept bright by using soap and water or polishing the silver with any silver polish.

SINGE MARKS

A singe mark can be removed by rubbing vigorously with the flat side of a silver coin. Some singe marks can be removed by sponging with a 3 percent solution of hydrogen peroxide and drying in direct sunlight. Never use this treatment on wool or dyed fabrics. Cuts, burns, or moth holes can be rewoven by a skillful tailor, who takes thread from another part of the garment; the shiny spots on serge can be removed by first sponging with a 1:20 solution of ammonia, then covering with a damp cloth, pressing with a hot iron, and rubbing gently with "00" sandpaper or emery cloth, but it's best to let an experienced tailor do this.

MEDALS

The surfaces of decorations are protected with an oxidized satin finish and a lacquer coating. They will not tarnish, and need no polishing; polishing may remove the finish. Medals may be cleaned with soap and water. The ribbons may be dry-cleaned, or replaced.

MOTHS

The best way to discourage moths is to brush clothing frequently and expose it to sunshine and fresh air when possible. If clothing is to be stored for any time, pack items in airtight plastic bags with camphor balls, naphthalene, or cedar wood.

MILDEW

New mildew can be washed out with cold water. Old stains in white cotton can be removed with a household laundry bleach.

STAINS

It is possible to stain a uniform with anything from alcohol to zinc chromate, but if you know what made the stain, an expert cleaner can remove it. In the way of first aid to a uniform before it goes to the cleaner, try soap and water - cool water for wool and warm water for cotton.

Dress uniforms should always be professionally dry-cleaned. Never apply a hot iron directly to dress uniforms; if pressing is required between dry-cleaning, place a damp cloth over the area to be pressed prior to ironing. When caring for all uniforms, always look for care and cleaning instructions on the label, and follow them strictly.

The following specific hints may assist you in the general care of uniform items:

A. OIL OR GREASE

Put clean cloth or absorbent paper under the garment, apply commercial cleaning fluid (or lighter fuel) to the stain, and tamp it, driving the oil or grease through to the cloth or paper. If the stain is heavy, shift the cloth to a clean place and use more cleaning fluid. To avoid a ring around the stain, wet a clean cloth with cleaning fluid and sponge lightly, working outward from the center of the area.

B. PAINT

Fresh paint should be handled as if it were oil or grease. Once it is dry and hard, the uniform should be sent to a professional cleaner. If this is not possible, apply turpentine and let it stand for an hour, then use a spoon or some other blunt object to break up the paint and flush it out as done for oil and grease. (Never rub when spotting fabric; this will leave a chafed area, with subsequent damage to color and weave. Always use a tamping action with a brush.)

C. PARAFFIN OR WAX

Put blotting paper over the spot and apply a hot iron. Continue, using clean blotting paper, until the spot is soaked up.

CARE OF OPERATIONAL DRESS UNIFORM SHIRTS

Pre-shrink U.S. Coast Guard Auxiliary Tapes and Name Tapes before sewing them onto your ODU or Working Blue uniforms. Rinse each tape in warm water for 2 minutes and lay them out flat to dry. In other words, if you get a new shirt and new name tape, throw both into the washer/dryer a few times before you actually get the tapes affixed to the shirt. The reason for this is that the shirt and tape may not wear the same way, and you might end up with a nametape that makes the shirt all wrinkly around the edges. The wash process should be done at least 3-4 times before you sew on the tapes.

For future spots, consult the Soap and Detergent Association's stain-removal guide at: <http://www.sdahq.org/laundry/fact/staintable.html>

DEVICES: USE AND MAINTENANCE TRICK FROM MEMBERS

Nametags, ribbons, and certain devices can be prevented from "flopping" by using a backing. This makes your uniform shirts look "high speed". Exchanges carry backing material, which you wear inside the shirt, cut to the device size. As an alternative, use thin white cardboard or plastic, such as that from a margarine container lid.

SHIRTS: PUTTING CREASES IN YOUR SHIRTS

Military creases may be worn at the member's option.

For military creases, you do not need the dry cleaner! It's easy! On the front of the shirt, iron a crease straight up and down centered through the pocket flap buttons from the collar to the tails/bottom. Thus, you will end up with 2 creases down the front of the shirt. Needless to say the "point" of the crease faces outwards.

For the back of the shirt, find the center of the shirt, and crease from about 2 inches below the collar (the yoke) to the bottom. Once that is ironed, carefully pick up the shirt and align the two side seams, which help you find the exact center of the shirt. That is dampened and ironed. The two side seams are established as near to half way between the center crease and the sleeve seam as possible. A quick spray (use spray bottle with tap water), and then fold a line parallel to the center crease. Repeat for the other side of the shirt. The "secret" is to only iron the crease, about 1 inch of material, not the entire area. This helps you avoid over ironing a part of the shirt that might be under the area that you are ironing. Another version is to take a dollar bill and place it spread out lengthwise to each side to find the side creases. These creases will begin about an inch lower than the primary creases and go to the bottom. Thus, you will end up with three back creases.

NOTE: Sewn-in military creases are not authorized. Don't forget to press the sleeves!

SHOES/BOOTS:

Keep your black shoes shiny! Total investment under 5 dollars. Here's how: The Exchanges should have a few things you need: Polish, a Shoe Brush, and a Rag. Read the directions on whatever black polish you pick. If they differ, follow their directions, not mine. Basically, you apply a thicker layer first, allow it to dry for a few minutes, then brush that layer to create the base. Not much shine will appear after this layer. Then, you apply a thin layer. You don't need to let it dry. By gently sprinkling water on the new layer, then buffing it with a soft cloth, you will begin to develop a nice shine. You can repeat a few times if necessary. The only caveat in this process is, if you go too crazy with the buffing, you'll actually over buff your shoes, lose the shine, and have to start over.

UNIFORM: "CONSISTENCY and CONFORMANCE"

It is important to keep a sharp military appearance when in uniform. A poor uniform may reflect poorly on you, but that's the least of the reasons for wearing a properly coordinated uniform. An uncoordinated uniform reflects poorly on the United States Coast Guard, the Reserve, the Auxiliary, and the military in its entirety.

Pencils, pens, watch chains, pins, combs, smoking material, or jewelry (i.e. necklace/chains except for rings) are not to be worn or carried exposed on a uniform. Wristwatches and identification bracelets are permitted. Earrings are prohibited for men in uniform under any circumstances, and are prohibited in civilian clothing aboard any vessel, aircraft or on any military installation, or when directed to wear civilian clothing while on official duty. No other type of body piercing ornamentation is authorized for men or women. Women can wear only one (not multiple) pair of earrings at a time, ¼ inch maximum size round ball-style in gold, silver or pearl are authorized with all uniforms: when formal or dinner dress uniform is worn, ¼ inch maximum, diamond earrings are authorized.

The bottoms of trousers or slacks should touch the shoe tops from instep rearward. The socks must not be exposed when the wearer is standing.

Men's hair should be neat and clean, not touch the collar, (not square-back) and be away from the ears. Back of women's hair may touch but not fall below the bottom edge of the collar. Women's hair shall not show under the front brim of the cap or extend below the eyebrows when headgear is removed. A single ponytail is authorized for female members, as long as it does not detract from the uniform, extend beyond the top of the collar, exceed the bulk limit, or interfere with the wearing of headgear. No more than one braid shall be worn in the hair. Afro, natural, bouffant and other similar hairstyles are permitted, but exaggerated styles, including those with excess fullness or extreme height are not authorized. Eccentric styles or colors may not be worn while in uniform or in a duty status. Varying hairstyles are permitted provided these styles meet the criteria of bulk and do not interfere with the proper wearing of military headgear.

Throughout your Auxiliary career, there will be many opportunities to wear your uniform. You must have a clean, pressed uniform and meet personal appearance standards. Women's skirt hemline should end at crease in back of knee but can go no lower than 2 inches below the crease. Handbag style should be hand/over shoulder but can be shortened to wear over arm.

Windbreaker jackets are authorized for use with the tropical, winter dress, undress, and working uniforms. When worn, the jacket shall be zipped at least ⅔ the way up.

Wooly Pulley and Cardigan Sweaters may be worn with Service Dress Blue, Tropical Blue Long, Undress, and working uniforms. They cannot be worn as OUTER WEAR, on commercial transportation, parade, etc. They may be worn inter-office or inter-building only.

Men should only wear V-neck undershirts with the Tropical Blue Long, summer undress, and working blue uniform. With all open neck shirts (except flight suits and the ODU) your undershirt or garment should not be showing. Are all your buttons buttoned (dress jackets are only worn buttoned, never open and hanging loose); is your hair too long and untidy; are your shoes shined; are your hands always in your pockets; are your trousers pressed to show the crease front and back; if outdoors - is your cap or hat on (it should be)?

SUGGESTIONS:

Are appreciated and considered. Because we add some of your suggestions and because the Coast Guard Auxiliary regulations change, the UPG is constantly being updated. You may wish to periodically confirm you have the most current information, by going to the Personnel Department website at <http://www.auxpdept.org/> or the Uniform Division web page at <http://www.auxpdept.org/uniform.htm> and click on the UPG link. All updates are done on an as required basis by the DVC- PX, UNIFORMS.

TO PONDER:

You represent the United States Coast Guard, Coast Guard Reserve, Coast Guard Auxiliary, and the Civilian Coast Guard Family. This is a huge responsibility as a member of the Coast Guard Auxiliary to live up to. The public (our customers) will be watching and your appearance will affect people's attitudes toward you, your mission, and more importantly the United States Coast Guard Mission.

SEMPER PARATUS

Copies may be made of all information in this guide.

Christopher E. Bonner, Division Chief
Uniform Division, Department of Personnel
Mail to: pelagic200@aol.com

INDEX (A-G)

A

Accessories	10
Air Force Exchange, <i>see Vendors</i>	
All Weather Parka.....	6-9, 10, 19
Parka I Availability	28
Parka II Availability	29, 30
Army Exchange, <i>see Vendors</i>	
Auxiliary Manual.....	5, 9, 32

B

Ball Cap, <i>see Caps</i>	
Belts	6, 8, 10, 13, 19
Availability	20
with Buckle	13
Blazers	
Availability.....	26
Blazer Patches.....	20
Boating Safety Booths, <i>see Occasions</i>	
Boots, <i>see Shoes</i>	
Breast Devices	39
Availability.....	20
Placement	12
Buckle.....	13
Buttons	
Availability.....	20
Maintenance	33

C

Caps, <i>see also Hats</i>	6-9, 13, 24
Accessories.....	20
Availability, <i>see Vendors</i>	
Ball Cap.....	19
Cold Weather Cap.....	19
Combination Cap.....	20
Covers.....	20
Comb Cap Frames	20
Garrison Caps.....	11, 20
Protocol	13, 19
Watch Cap.....	19
Cap Devices	
Maintenance	37

Cardigan Sweaters.....	6-9, 19, 41
Availability	20

Classroom, *see Occasions*

Cleaning, *see Maintenance*

Coast Guard Exchange, *see Vendors*

Coats.....	6-9
Availability	23, 25

Cold Weather Cap, *see Caps*

Collar Insignia.....	6-9, 33
Availability	32-35
Positioning	11

Collar Pins, *see Pins*

Comb Cap Frames, *see Caps*

Combination Cap, *see Caps*

Coveralls	26
-----------------	----

Cummerbunds	26
-------------------	----

D

Dinner Dress White/Black Jacket Uniform	
Men.....	7
Women.....	9

Distribution Centers, *see Vendors*

Division Chief of Uniforms	
Contact Information.....	15

Dress Uniforms, *see Dinner Dress, Service Dress, Winter Dress*

Availability	23, 25-26
--------------------	-----------

F

Formal Affairs, *see Occasions*

G

Garrison Cap	
Availability, <i>see Caps</i>	
Positioning	11

Gloves	6-10, 19
--------------	----------

INDEX (H-Si)

H

Hair	40
Handbags	40
Hats, <i>see also Caps, Vendors</i>	6-9, 13, 24
Bands	20
Tilley Hat.....	20
Vinyl Hat Cover	24

I

Informal Wear, Protocol	19
Insignia	6-9, 20
Availability, <i>see Vendors</i>	
Collar Insignia, <i>see Collar Insignia</i>	
Rank Specific Devices.....	20, 32-35
Shoulder Boards, <i>see Shoulder Boards</i>	

J

Jackets.....	6-9
Availability.....	23, 25
Jewelry	40
Jumpsuit.....	26

M

Maintenance, of Uniforms	37-39
Medals.....	6-9
Availability.....	20
Maintenance	38
Positioning.....	12
Meetings, <i>see Occasions</i>	
Men's Uniforms.....	6-7
Mildew, <i>see Maintenance</i>	
Military Exchange Stores, <i>see Vendors</i>	
Moths, <i>see Maintenance</i>	

N

Name Tags	6-9
Maintenance	39
Placement	12
Name Tapes	6, 8, 39
Availability.....	32, 33

Navy Exchange, *see Vendors*

O

Occasions	6-9
Operational Dress Uniform	5, 6, 8
Maintenance.....	39
Outer Garments	6-9

P

Personnel Department	3, 5, 41
Personal Floatation Device.....	19, 33
Pins	
Collar.....	24
Raincoat	24

Q

Qualification Devices.....	6-9
Placement.....	12

R

Ribbons	6-9
Availability	20
Magnetic.....	31
Maintenance	39
Placement.....	12

S

Scarves, *see Accessories*

Service Dress Blue Uniform

Alpha	7, 9
Bravo	
Men.....	7
Women.....	9

Shirts	5-9, 19
Availability	21, 26
Collar Positioning	11
Ribbon Positioning	12
Maintenance.....	37-39
Proper Wear	40

Shoes	6-9, 19
Maintenance.....	39

Shoulder Boards	6-9
Availability	
Enhanced Boards	8, 26
Hard Boards	8, 26

Silver Lace	
Maintenance.....	1

Singe Marks, *see Maintenance*

INDEX (Sk-W)

Skirts.....8-9	Bravo
Slacks.....8-9	Men.....6
Sleeve Striping.....24	Women.....8
Socks.....6-9, 40	Undress Blue Winter Uniform
Special Measurements, <i>see USCG Distribution Center</i>	Men.....6
Stains, <i>see Maintenance</i>	Women.....8
Stockings, <i>see Socks</i>	Used Uniforms16, 18
Sweaters, <i>see Accessories, Cardigan Sweaters, Woolly-Pully</i>	
T	V
Tailoring, <i>see USCG Distribution Center, Vendors</i>	Vendors14-36
Ties6-9, 19-23	Caps:
Tropical Blue Long Uniform5, 12, 25, 26	Uniform Cap Company.....22
Men.....7	Insignia / Name Tapes32-36
Women9	DeeBees's Tailoring & Cleaners34
Trousers.....6-7, 21, 25-26	The Bent Needle33
Tunic.....23	Uniform Name Tape Company.....35
Tuxedo Attire.....26	Wings and Things Monogramming36
U	Ribbons:
Undershirts, <i>see Accessories</i>	Ultra Thin Ribbons & Medals31
Uniform Procurement Guide3-4	Uniforms:
Obtaining3-4	Lighthouse Uniform Company25-27
Policy.....3-4	Military Exchange Stores.....14-23
Purpose.....5	Locating19
Web access5	Protocol.....19
USCG Auxiliary Center.....20	Propper International26
USCG Uniform Distribution Center14-16	USCG Academy Clothing Locker23
Ordering14-15	USCG Auxiliary Center.....20
Refunds.....16	USCG Uniform Dist. Center.....14-16
Returns15	US Navy Uniform Support Center.....23
Shipping15	Vessel Safety Checks, <i>see Occasions</i>
Special Measurement Program.....16	W
Used Uniforms16	Watch Cap, <i>see Caps</i>
Undress Blue Summer Uniform	Windbreaker.....6-9
Alpha	Availability19
Men.....6	Winter Dress Blue Uniform7
Women8	Men.....7
	Women.....9
	Women's Uniforms8-9
	Wooly Pully6-9, 19
	Availability26
	Working Blue Uniform6
	Men.....6
	Women.....8

"It's Your Auxiliary
It's Your Uniform
Wear it with **Pride!**"



An Integral Part of the
United States Coast Guard
Family